

# Varistor: TVR-U Series

## Disc Type Varistor for Surge Protection (Ultra High Surge Series)



### ■ Features

1. Body size:  $\Phi 10\text{mm}$ ,  $\Phi 14\text{mm}$
2. Compact product design saves 30% and 45% installation space when comparing with  $\Phi 14\text{mm}$  and  $\Phi 20\text{mm}$  varistors
3. 8/20 $\mu\text{s}$  high surge current ( $I_{\text{max}}$ ) of  $\Phi 10\text{mm}$  and  $\Phi 14\text{mm}$  products are 6,000A and 10,000A
4. Wide operating voltage range: 150Vac-680Vac
5. RoHS compliant
6. Operating temperature range:  $-40^{\circ}\text{C} \sim +125^{\circ}\text{C}$   
Storage temperature range:  $-40^{\circ}\text{C} \sim +150^{\circ}\text{C}$
7. Agency recognition: UL/TUV/CQC

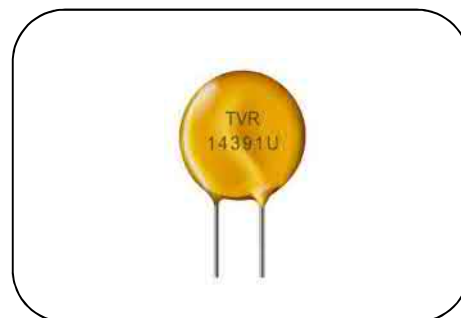

### ■ Recommended Applications

1. Power supply
2. Power supply for home appliance
3. Industrial equipment
4. Telecommunication system

### ■ Part Number Code

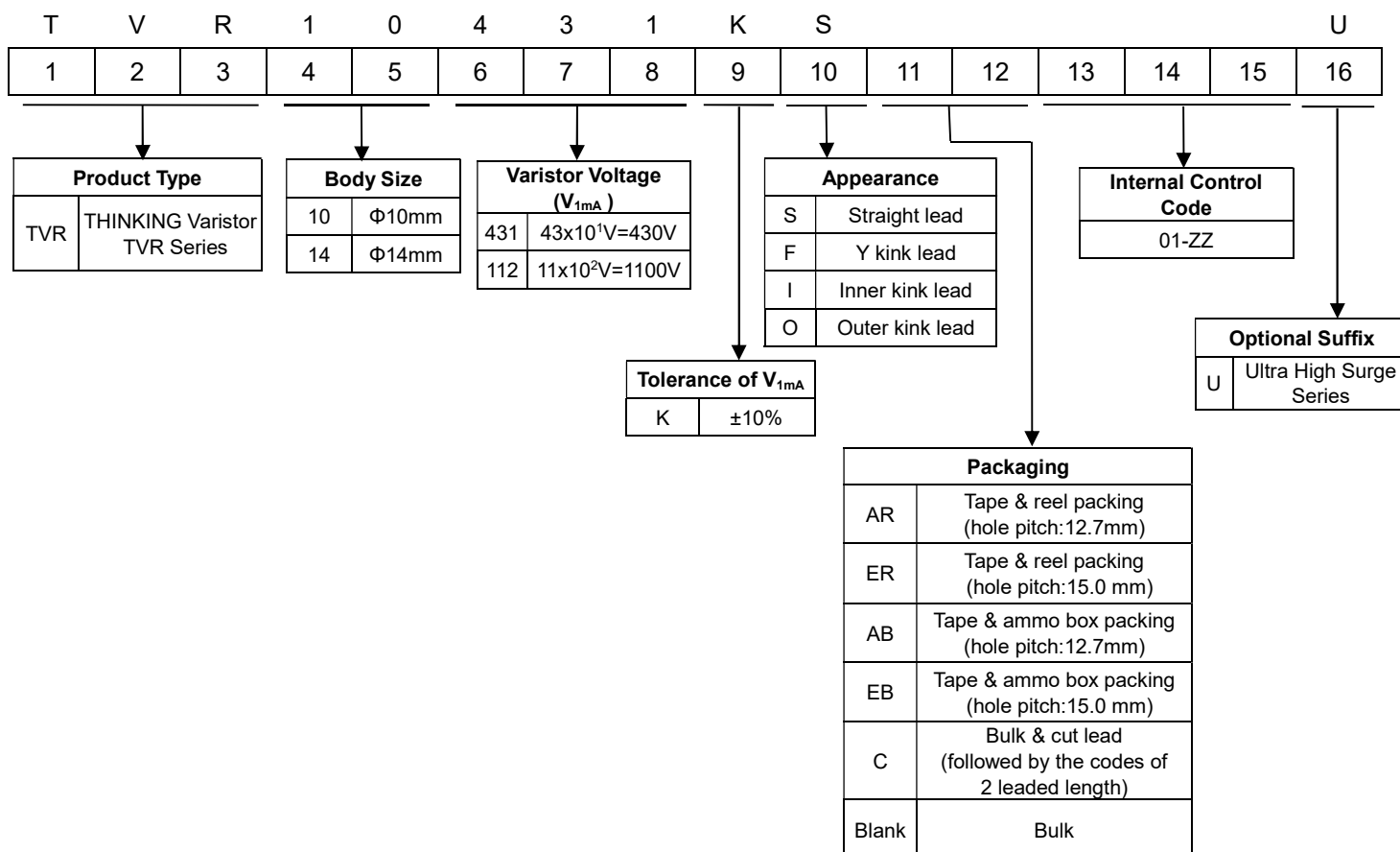

# Varistor: TVR-U Series

## Disc Type Varistor for Surge Protection (Ultra High Surge Series)



### Structures and Dimensions

#### S Type (Straight lead)

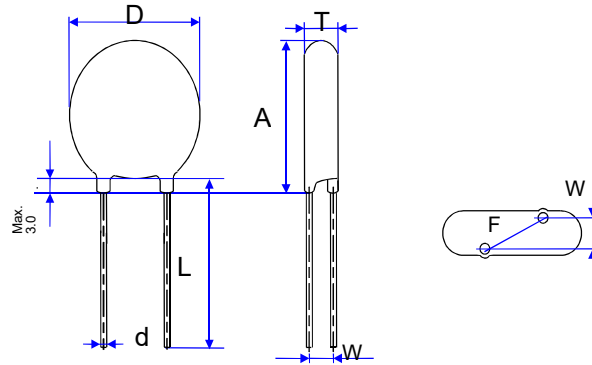

(Unit:mm)

Series	D <sub>max.</sub>	L <sub>min.</sub>	d	F	A <sub>max.</sub>	T1	W
TVR10-U	14	15	0.8±0.05	7.5±0.5 (for TVR10241-U-TV10561-U) 7.5±1.0 (for TVR10621-U-TV10112-U)	17	Please refer to Electrical Characteristics Table	
TVR14-U	18	15	0.8±0.05	7.5±0.5 (for TVR14241-U-TV14561-U) 7.5±1.0 (for TVR14621-U-TV14112-U)	21.5		

#### F Type (Y kink lead)

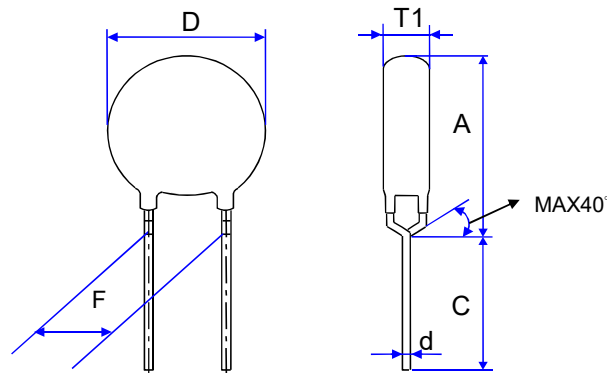

(Unit: mm)

Series	D <sub>max.</sub>	C <sub>min.</sub>	d	F	A <sub>max.</sub>	T1	W
TVR10-U	14	15	0.8±0.05	7.5±0.5 (for TVR10241-U-TV10561-U) 7.5±1.0 (for TVR10621-U-TV10112-U)	17	Please refer to Electrical Characteristics Table	
TVR14-U	18	15	0.8±0.05	7.5±0.5 (for TVR14241-U-TV14561-U) 7.5±1.0 (for TVR14621-U-TV14112-U)	22		

# Varistor: TVR-U Series

## Disc Type Varistor for Surge Protection (Ultra High Surge Series)



### ■ O Type (Outer kink lead)

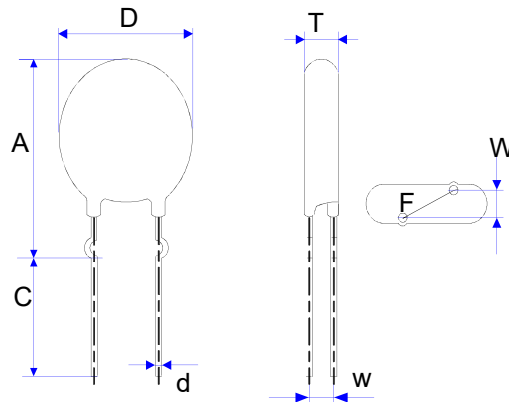

(Unit: mm)

Series	D <sub>max.</sub>	C <sub>min.</sub>	d	F	A <sub>max.</sub>	T1	W
TVR10-U	14	15	0.8±0.05	7.5±0.5 (for TVR10241-U-TV10561-U) 7.5±1.0 (for TVR10621-U-TV10112-U)	22	Please refer to Electrical Characteristics Table	
TVR14-U	18	15	0.8±0.05	7.5±0.5 (for TVR14241-U-TV14561-U) 7.5±1.0 (for TVR14621-U-TV14112-U)	24.5		

### ■ I Type (Inner kink lead)

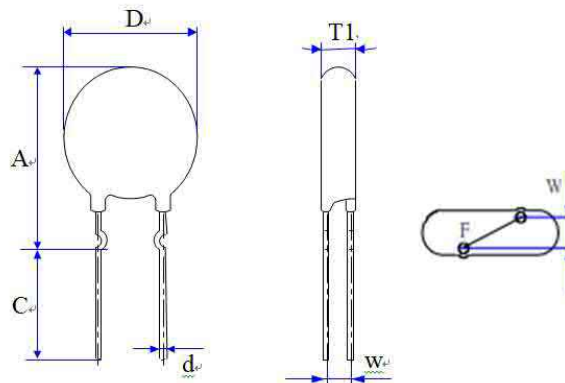

(Unit: mm)

Series	D <sub>max.</sub>	C <sub>min.</sub>	d	F	A <sub>max.</sub>	T1	W
TVR10-U	14	15	0.8±0.05	7.5±0.5 (for TVR10241-U-TV10561-U) 7.5±1.0 (for TVR10621-U-TV10112-U)	22	Please refer to Electrical Characteristics Table	
TVR14-U	18	15	0.8±0.05	7.5±0.5 (for TVR14241-U-TV14561-U) 7.5±1.0 (for TVR14621-U-TV14112-U)	24.5		

# Varistor: TVR-U Series

## Disc Type Varistor for Surge Protection (Ultra High Surge Series)



### ■ Electrical Characteristics

#### 10mm Series

Part No.	Varistor Voltage (@ 1mA DC)	Max. Continuous Voltage		Max. Clamping Voltage (8/20μs)		Max. Surge Current (8/20μs)	Rated Power	Max. Energy (10/1000μs)	Dimension		
	V <sub>1mA</sub>	V <sub>AC(rms)</sub>	V <sub>DC</sub>	V <sub>P</sub>	I <sub>P</sub>	I <sub>max</sub>	P	W <sub>max</sub>	T <sub>min</sub>	T <sub>max</sub>	W ±1.0
	(V)	(V)	(V)	(V)	(A)	(A)	(W)	(J)	(mm)		
TVR10201-U	205 (184.5~225.5)	130	--	340	50	6000	0.6	84	2.9	4.4	1.3
TVR10221-U	220 (198~242)	140	--	360				91	3.0	4.5	1.4
TVR10241-U	240 (216-264)	150	200	395				98	3.1	4.7	1.5
TVR10271-U	270 (243-297)	175	225	455				112	3.3	4.9	1.8
TVR10301-U	300 (270-330)	195	250	500				123	3.4	5.1	1.9
TVR10331-U	330 (297-363)	215	275	550				133	3.5	5.3	2.1
TVR10361-U	360 (324-396)	230	300	595				147	3.6	5.5	2.3
TVR10391-U	390 (351-429)	250	320	650				161	3.7	5.6	2.4
TVR10431-U	430 (387-473)	275	350	710				182	3.8	5.9	2.5
TVR10471-U	470 (423-517)	300	385	775				196	3.9	6.2	2.6
TVR10511-U	510 (459-561)	320	420	845				210	4.1	6.5	2.7
TVR10561-U	560 (504-616)	350	460	930				231	4.2	7.0	2.8
TVR10621-U	620 (558-682)	395	510	1020				252	4.5	7.4	3.0
TVR10681-U	680 (612-748)	420	560	1120				266	4.7	8.1	3.0
TVR10751-U	750 (675-825)	465	615	1235				280	5.0	8.6	3.1
TVR10781-U	780 (702-858)	485	640	1300				280	5.1	9.0	3.3
TVR10821-U	820 (738-902)	510	670	1355				280	5.2	9.2	3.4
TVR10911-U	910 (819-1001)	550	745	1500				308	5.6	9.9	3.7
TVR10102-U	1000 (900-1100)	625	825	1650				336	5.9	10.4	4.0
TVR10112-U	1100 (990-1210)	680	895	1815				364	6.3	11.1	4.4

# Varistor: TVR-U Series

## Disc Type Varistor for Surge Protection (Ultra High Surge Series)



### Electrical Characteristics

#### 14mm Series



Part No.	Varistor Voltage (@ 1mA DC)	Max. Continuous Voltage		Max. Clamping Voltage (8/20μs)		Max. Surge Current (8/20μs)	Rated Power	Max. Energy (10/1000μs)	Dimension		
	V <sub>1mA</sub>	V <sub>AC(rms)</sub>	V <sub>DC</sub>	V <sub>P</sub>	I <sub>P</sub>	I <sub>max</sub>	P	W <sub>max</sub>	T <sub>min</sub>	T <sub>max</sub>	W ±1.0
	(V)	(V)	(V)	(V)	(A)	(A)	(W)	(J)	(mm)		
TVR14241-U	240 (216-264)	150	200	395	100	10000	1.0	168	3.1	5.1	1.5
TVR14271-U	270 (243-297)	175	225	455				190	3.3	5.3	1.8
TVR14301-U	300 (270-330)	195	250	500				210	3.4	5.5	1.9
TVR14331-U	330 (297-363)	215	275	550				228	3.5	5.7	2.1
TVR14361-U	360 (324-396)	230	300	595				255	3.6	5.9	2.3
TVR14391-U	390 (351-429)	250	320	650				275	3.7	6	2.4
TVR14431-U	430 (387-473)	275	350	710				303	3.8	6.1	2.5
TVR14471-U	470 (423-517)	300	385	775				350	3.9	6.3	2.6
TVR14511-U	510 (459-561)	320	420	845				382	4.1	6.5	2.7
TVR14561-U	560 (504-616)	350	450	930				382	4.2	7.0	2.8
TVR14621-U	620 (558-682)	395	510	1020				382	4.5	7.4	3.0
TVR14681-U	680 (612-748)	420	560	1120				382	4.7	8.1	3.0
TVR14751-U	750 (675-825)	465	615	1235				420	5.0	8.6	3.0
TVR14781-U	780 (702-858)	485	640	1300				440	5.1	9.0	3.3
TVR14821-U	820 (738-902)	510	670	1355				460	5.2	9.2	3.4
TVR14911-U	910 (819-1001)	550	745	1500				510	5.6	9.9	3.7
TVR14102-U	1000 (900-1100)	625	825	1650				565	5.9	10.0	4.0
TVR14112-U	1100 (990-1210)	680	895	1815	620	6.3	11.1	4.4			

# Varistor: TVR-U Series

## Disc Type Varistor for Surge Protection (Ultra High Surge Series)



### ■ Safety Approvals



Certified Model No.	Agency				
					
	UL1449 5 <sup>th</sup> & cUL	EN/IEC 61051-1, IEC 61051-2, IEC 61051-2-2	IEC62368-1 Annex G.8.1	GB/T10193-1997 GB/T10194-1997	GB8898-2011 GB4943.1-2011
	E314979	J50531421		CQC22001335732	
TVR10241-U	√	√	√	√	
TVR10271-U	√	√	√	√	
TVR10301-U	√	√	√	√	
TVR10331-U	√	√	√	√	
TVR10361-U	√	√	√	√	
TVR10391-U	√	√	√	√	
TVR10431-U	√	√	√	√	√
TVR10471-U	√	√	√	√	√
TVR10511-U	√	√	√	√	√
TVR10561-U	√	√	√	√	√
TVR10621-U	√	√	√	√	√
TVR10681-U	√	√	√	√	√
TVR10751-U	√	√	√	√	√
TVR10781-U	√	√	√	√	√
TVR10821-U	√	√	√	√	√
TVR10911-U	√	√	√	√	√
TVR10102-U	√	√	√	√	√
TVR10112-U	√	√	√	√	√

# Varistor: TVR-U Series

Disc Type Varistor for Surge Protection (Ultra High Surge Series)



## ■ Safety Approvals

Certified Model No.	Agency				
					
	UL1449 5 <sup>th</sup> & cUL	EN/IEC 61051-1, IEC 61051-2, IEC 61051-2-2	IEC62368-1 Annex G.8.1	GB/T10193-1997 GB/T10194-1997	GB8898-2011 GB4943.1-2011
	E314979	J50531421		CQC22001335732	
TVR14241-U	√	√	√	√	
TVR14271-U	√	√	√	√	
TVR14301-U	√	√	√	√	
TVR14331-U	√	√	√	√	
TVR14361-U	√	√	√	√	
TVR14391-U	√	√	√	√	
TVR14431-U	√	√	√	√	√
TVR14471-U	√	√	√	√	√
TVR14511-U	√	√	√	√	√
TVR14561-U	√	√	√	√	√
TVR14621-U	√	√	√	√	√
TVR14681-U	√	√	√	√	√
TVR14751-U	√	√	√	√	√
TVR14781-U	√	√	√	√	√
TVR14821-U	√	√	√	√	√
TVR14911-U	√	√	√	√	√
TVR14102-U	√	√	√	√	√
TVR14112-U	√	√	√	√	√

# Varistor: TVR-U Series

Disc Type Varistor for Surge Protection (Ultra High Surge Series)



## Surge Current Standard Waveform

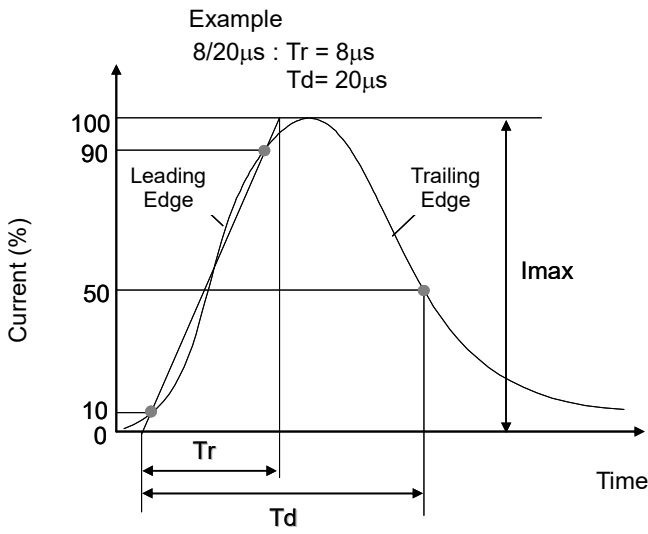

## Max. Surge Current Derating Curves

TVR10241-U to TVR10112-U

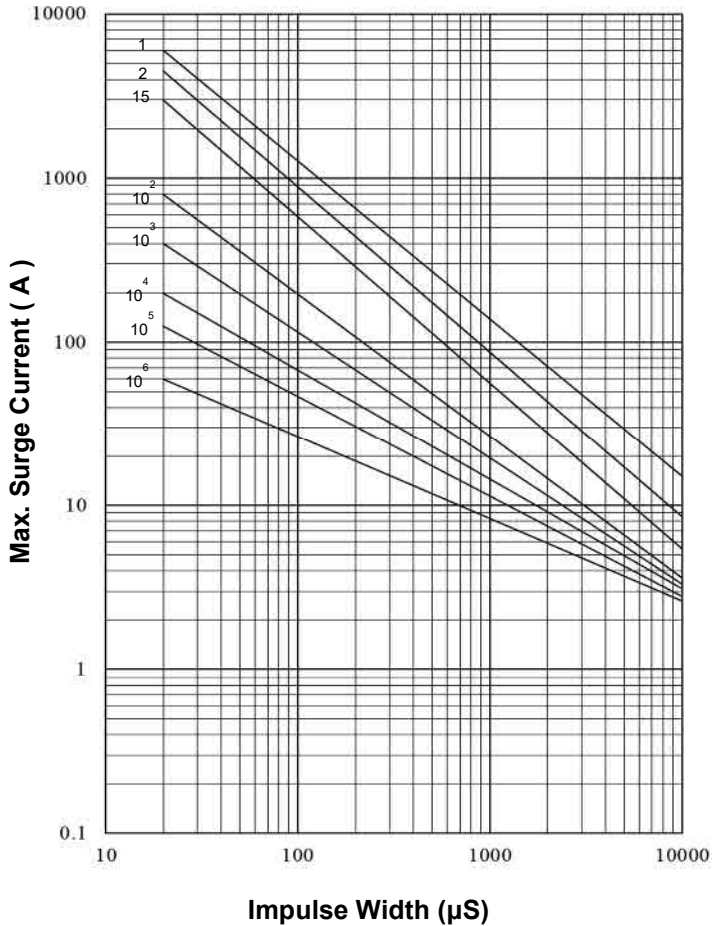

TVR14241-U to TVR14112-U

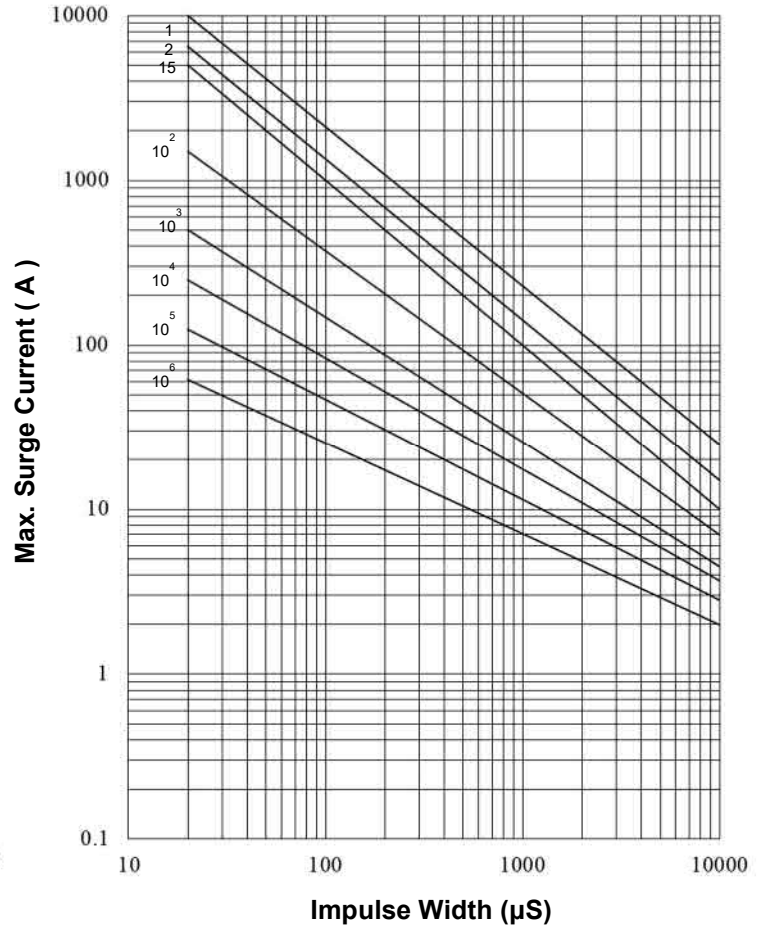



# Varistor: TVR-U Series

## Disc Type Varistor for Surge Protection (Ultra High Surge Series)



### ■ Max. Leakage Current and Max. Clamping Voltage Curves

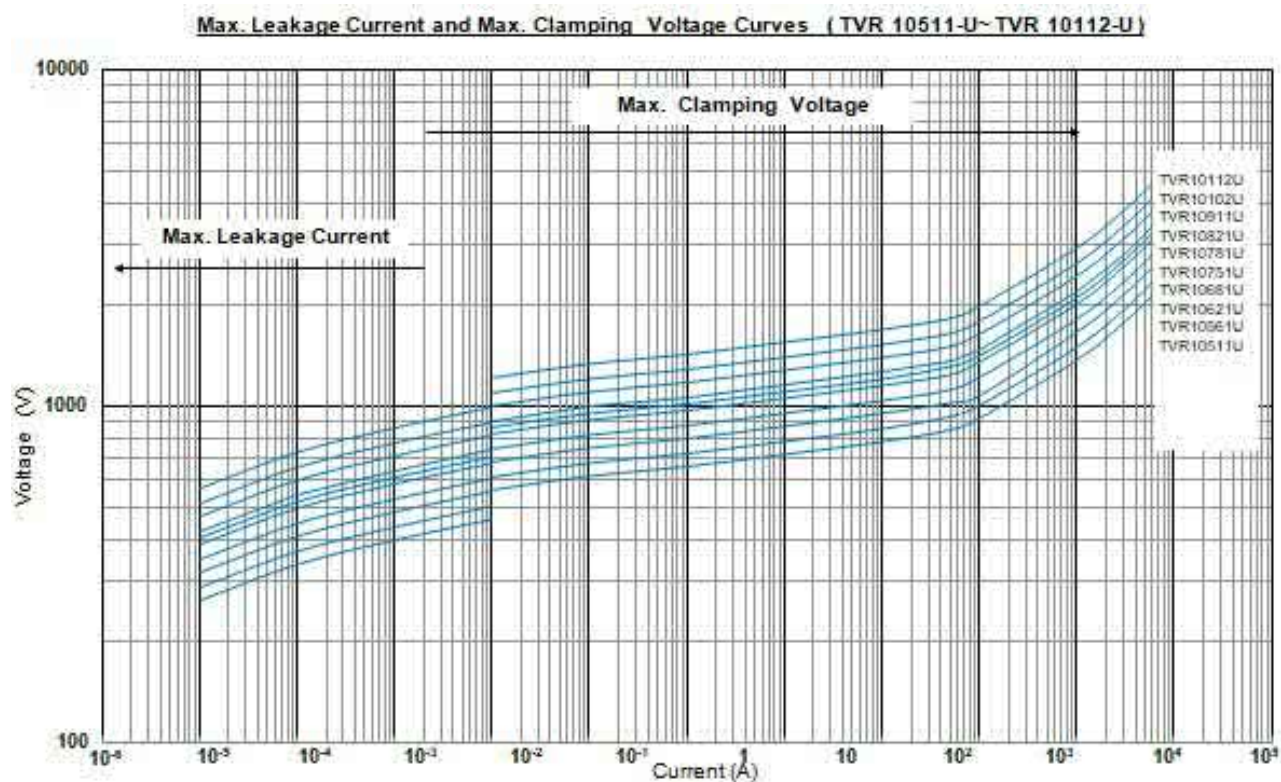
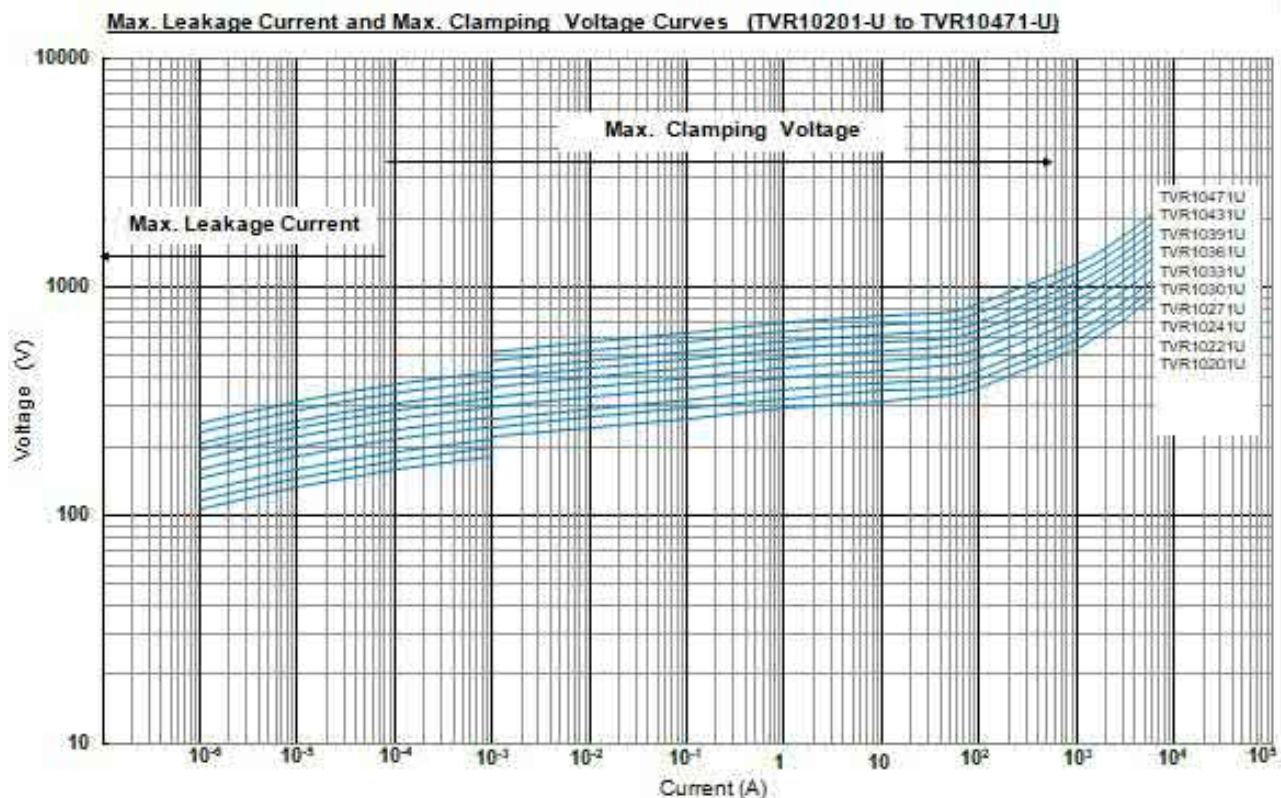

# Varistor: TVR-U Series

## Disc Type Varistor for Surge Protection (Ultra High Surge Series)



### ■ Max. Leakage Current and Max. Clamping Voltage Curves

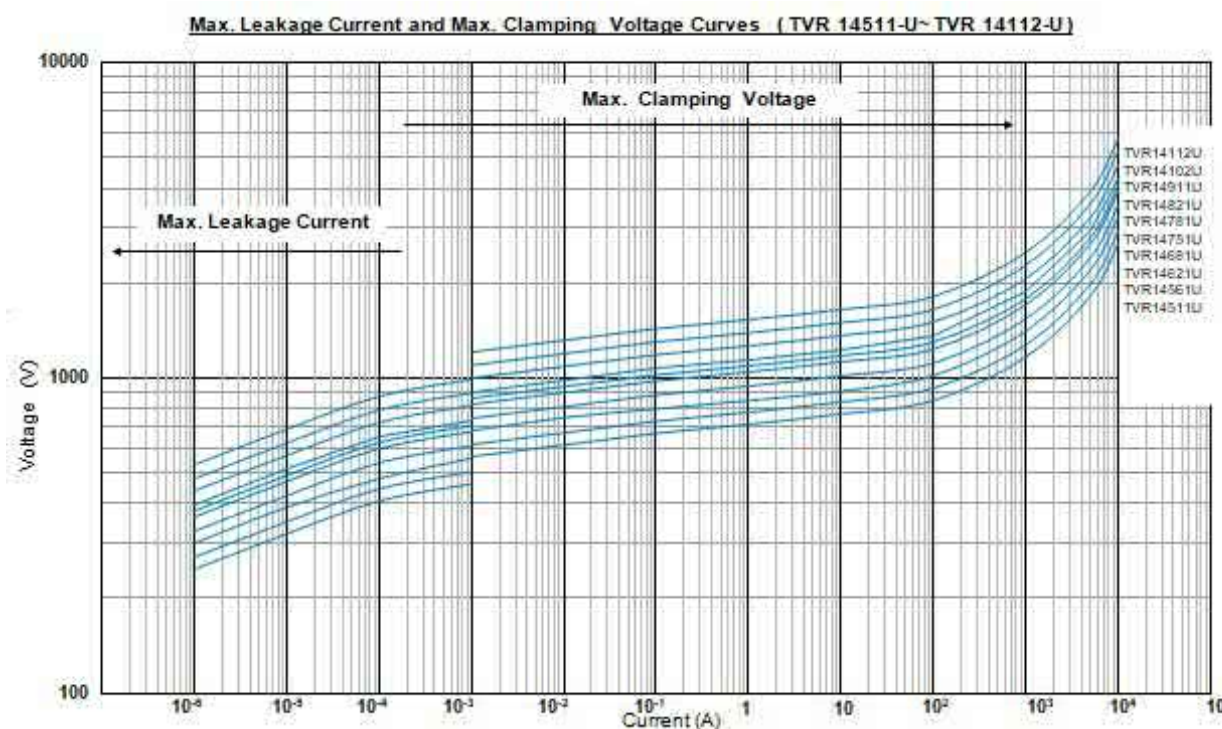
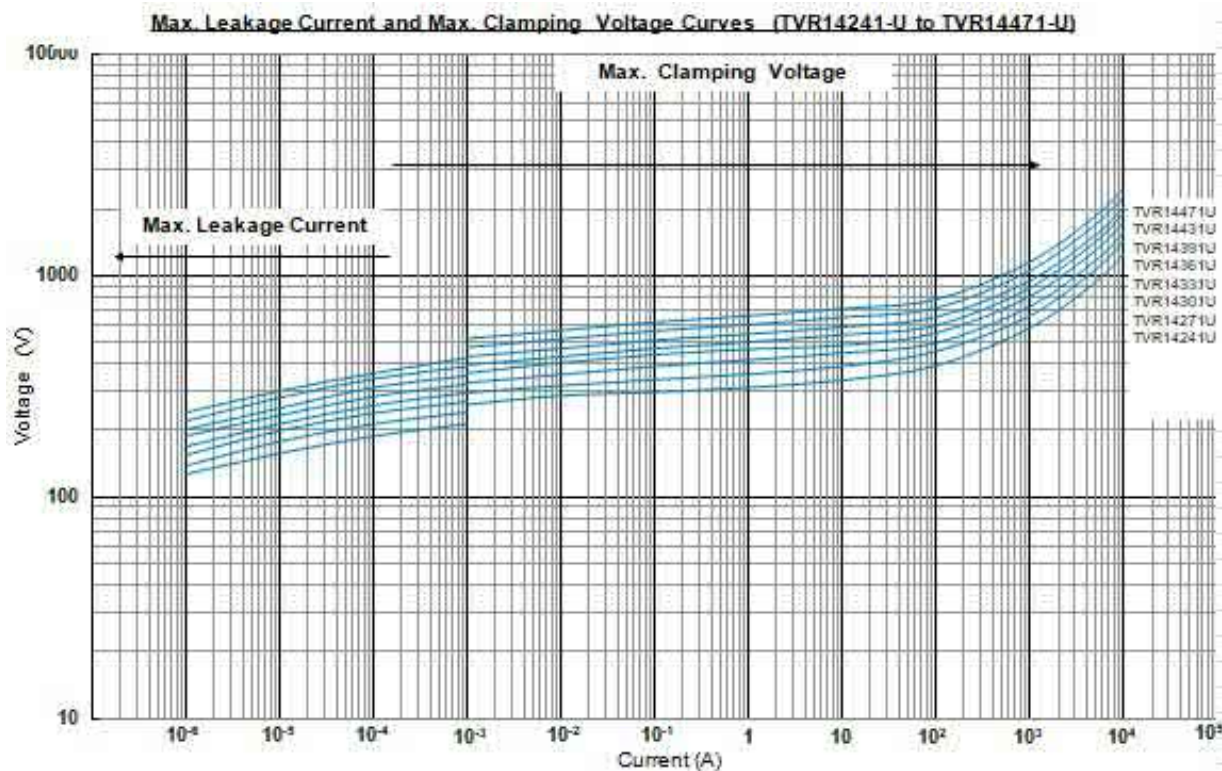

# Varistor: TVR-U Series

## Disc Type Varistor for Surge Protection (Ultra High Surge Series)



### ■ Soldering Recommendation

#### ● IR-reflow Soldering Profile

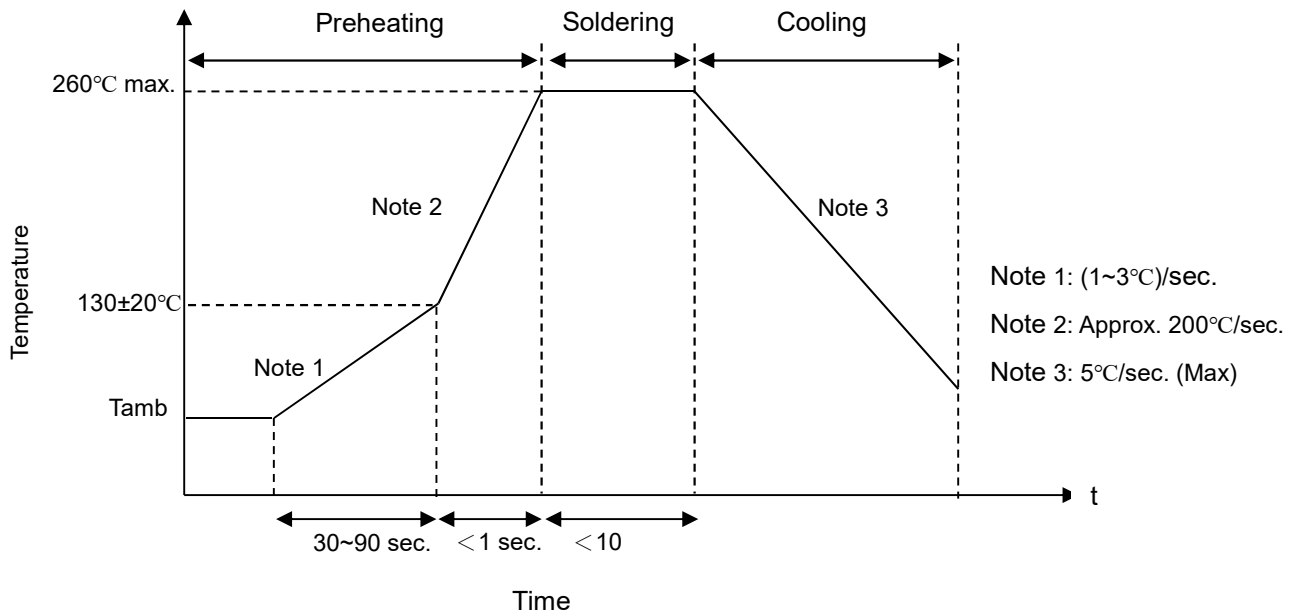

#### ● Recommended Reworking Conditions with Soldering Iron

Item	Conditions
Temperature of Soldering Iron-tip	360°C (max.)
Soldering Time	3 sec (max.)
Diameter of Soldering Iron-tip	Φ3 mm (max.)

# Varistor: TVR-U Series

## Disc Type Varistor for Surge Protection (Ultra High Surge Series)



### ■ Reliability

Item	Standard	Test conditions / Methods	Specifications															
Tensile Strength of Terminals	IEC60068-2-21	Gradually apply the specified force and keep the unit fixed for 10±1 sec.  Terminal diameter (mm)                      Force (Kg) 0.5<d ≦ 0.8                                      1.0 0.8<d ≦ 1.25                                      2.0	$ \Delta V_{1mA}/V_{1mA}  \leq \pm 5\%$ No visible damage															
Bending Strength of Terminals	IEC 60068-2-21	Hold specimen and apply the force specified below to each lead. Bend the specimen to 90°, then return to the original position. Repeat the procedure in the opposite direction.  Terminal diameter (mm)                      Force (Kg) 0.5<d ≦ 0.8                                      0.5 0.8<d ≦ 1.25                                      1.0	$ \Delta V_{1mA}/V_{1mA}  \leq \pm 5\%$ No visible damage															
Vibration	IEC 60068-2-6	Frequency range: 10Hz→55Hz→55Hz, 1 min Amplitude: 0.75mm, 6hrs	$ \Delta V_{1mA}/V_{1mA}  \leq \pm 5\%$ No visible damage															
Solderability	IEC 60068-2-20	245±3°C, 3±0.3 sec.	At least 95% of terminal electrode is covered by new solder															
Resistance to Soldering Heat	IEC 60068-2-20	260±3°C, 10±1 sec.	$ \Delta V_{1mA}/V_{1mA}  \leq \pm 5\%$ No visible damage															
High Temperature Storage	IEC 60068-2-2	150±2°C, 1000 hrs	$ \Delta V_{1mA}/V_{1mA}  \leq \pm 5\%$ No visible damage															
Damp Heat, Steady State	IEC 60068-2-78	a. 40±2°C, 90-95% RH, 1344 hrs. b. 40±2°C, 90-95% RH, at 10%Vdc, 1344 hrs	$ \Delta V_{1mA}/V_{1mA}  \leq \pm 5\%$ No visible damage															
Rapid Change of Temperature	IEC 60068-2-14	The conditions shown below shall be repeated 5 cycles <table border="1" style="margin-left: auto; margin-right: auto;"> <thead> <tr> <th>Step</th> <th>Temperature (°C)</th> <th>Period (minutes)</th> </tr> </thead> <tbody> <tr> <td>1</td> <td>-40±3</td> <td>30±3</td> </tr> <tr> <td>2</td> <td>Room temperature</td> <td>≦3</td> </tr> <tr> <td>3</td> <td>125±2</td> <td>30±3</td> </tr> <tr> <td>4</td> <td>Room temperature</td> <td>≦3</td> </tr> </tbody> </table>	Step	Temperature (°C)	Period (minutes)	1	-40±3	30±3	2	Room temperature	≦3	3	125±2	30±3	4	Room temperature	≦3	$ \Delta V_{1mA}/V_{1mA}  \leq \pm 5\%$ No visible damage
Step	Temperature (°C)	Period (minutes)																
1	-40±3	30±3																
2	Room temperature	≦3																
3	125±2	30±3																
4	Room temperature	≦3																
High Temp. Load	MIL-STD-202 Method 108	125°C, 1000±24 hrs at V <sub>rms</sub> (Max. Continuous Voltage)	$ \Delta V_{1mA}/V_{1mA}  \leq \pm 10\%$ No visible damage															
Voltage Proof	IEC 61051-1	Metal balls method, 2500 V <sub>ac</sub> 1 min	No visible damage															
Varistor Voltage Temp. Coefficient	Specification Standard	Varistor voltage is measured at -40°C, +125°C, and +25°C	-0.05 ≤ T <sub>c</sub> ≤ 0.05 (%/°C)															

# Varistor: TVR-U Series

## Disc Type Varistor for Surge Protection (Ultra High Surge Series)



### ■ Packaging

#### ● Taping Specification

#### S Type (Straight lead)

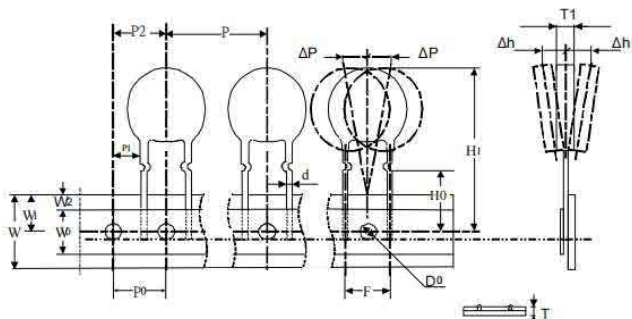

Figure A

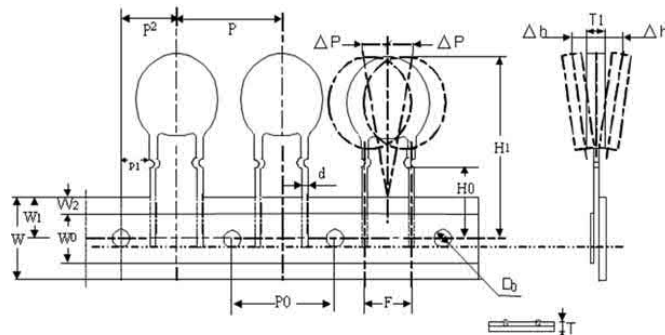

Figure B

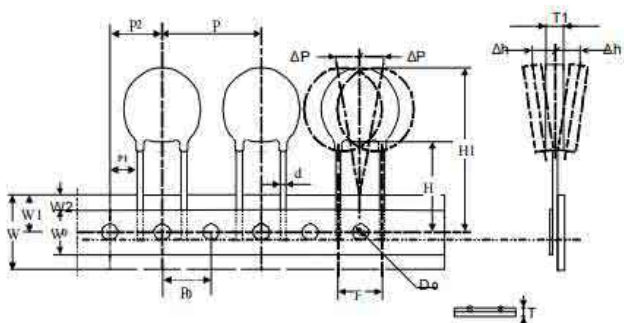

Figure C

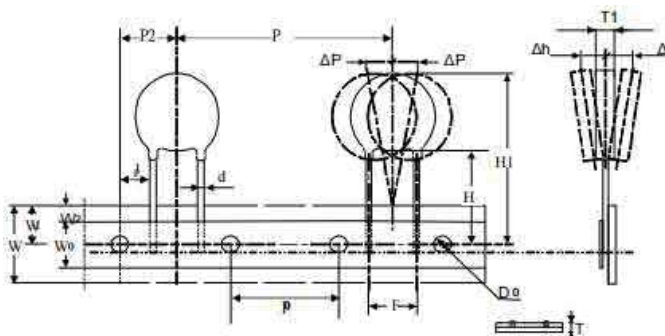

Figure D

Taping Code	Body Size	P0	F	P1	P2	P	H	H1	W0	W1	W2	W	ΔP	Δh	D0	d	T	Figure
		±0.3	±1	±1	±1.3	±1	+2/-0	Max	±1	+0.75/-0.5	Max	±1	Max	Max	±0.2	±0.05	±0.2	
A (P0:12.7)	10	12.7	7.5	8.55	12.7	25.4	18	36.0	12	9	3	18	1.0	2.0	4	0.8	0.6	A
E (P0:15)		15.0	7.5	3.35	7.50	15.0	18	36.0	12	9	3	18	1.0	2.0	4	0.8	0.6	B
A (P0:12.7)	14	12.7	7.5	8.55	12.7	25.4	18	40	12	9	3	18	1.0	2.0	4	0.8	0.6	C
E (P0:15)		15.0	7.5	3.35	7.50	30	18	40	12	9	3	18	1.0	2.0	4	0.8	0.6	D

# Varistor: TVR-U Series

## Disc Type Varistor for Surge Protection (Ultra High Surge Series)



### F Type (Y kink lead)

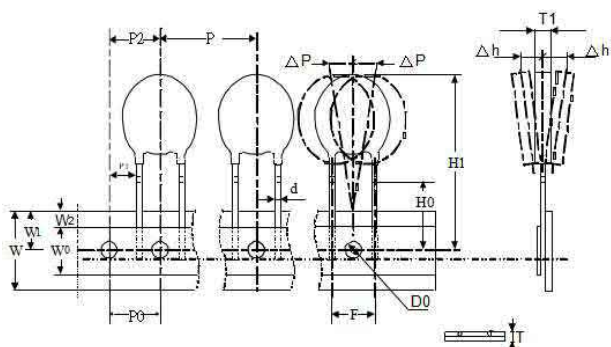

Figure A

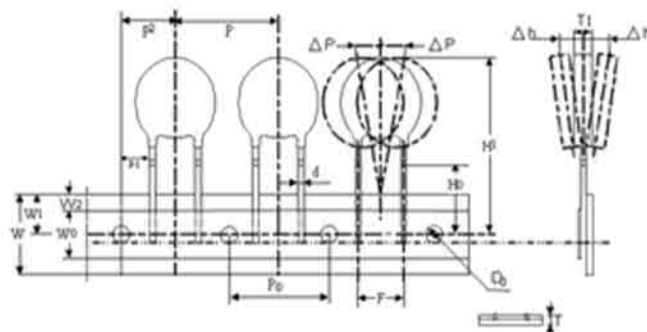

Figure B

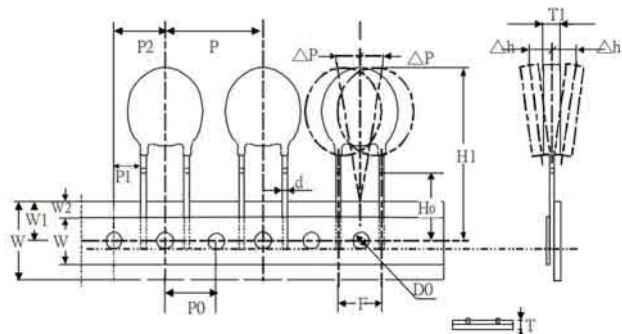

Figure C

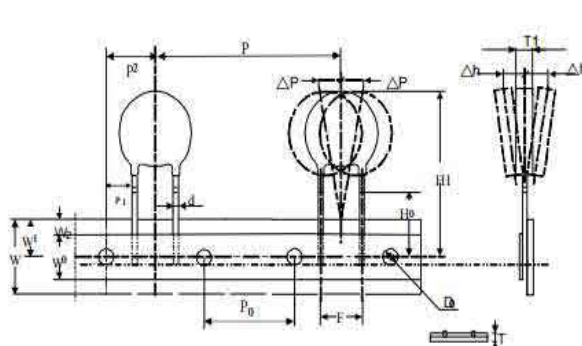

Figure D

(Unit: mm)

Taping Code	Body Size	P0	F	P1	P2	P	H0	H1	W0	W1	W2	W	ΔP	Δh	D0	d	T	Figure
		±0.3	±1	±1	±1.3	±1	±0.5	Max	±1	+0.75/-0.5	Max	±1	Max	Max	±0.2	±0.05	±0.2	
A (P0:12.7)	10	12.7	7.5	8.55	12.7	25.4	16	36.0	12	9	3	18	1.0	2.0	4	0.8	0.6	A
E (P0:15)		15.0	7.5	3.35	7.50	15.0	16	36.0	12	9	3	18	1.0	2.0	4	0.8	0.6	B
A (P0:12.7)	14	12.7	7.5	8.55	12.7	25.4	16	40	12	9	3	18	1.0	2.0	4	0.8	0.6	C
E (P0:15)		15.0	7.5	3.35	7.50	30	16	40	12	9	3	18	1.0	2.0	4	0.8	0.6	D

# Varistor: TVR-U Series

## Disc Type Varistor for Surge Protection (Ultra High Surge Series)



### O Type (Outer kink lead)

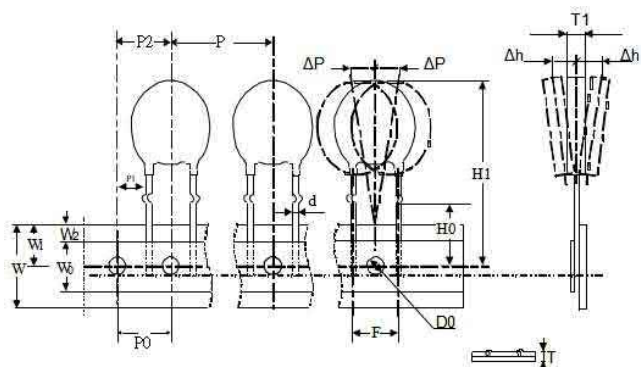

Figure A

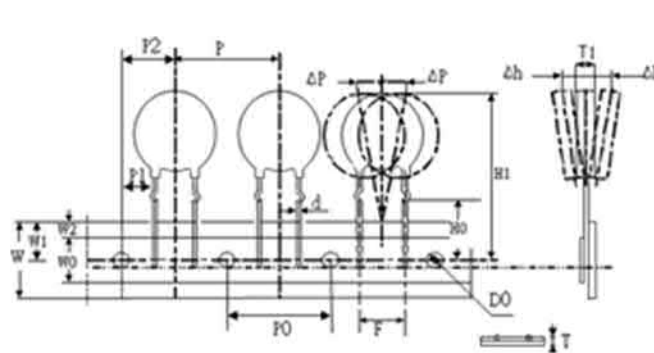

Figure B

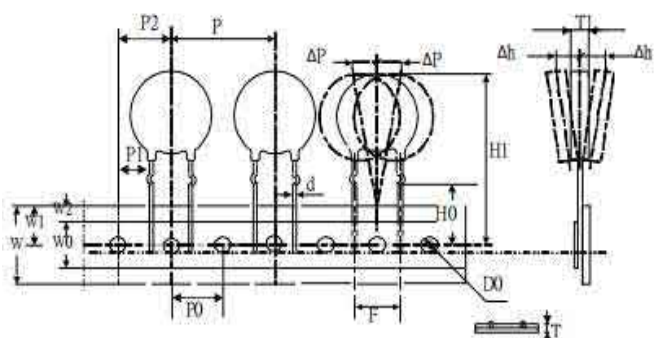

Figure C

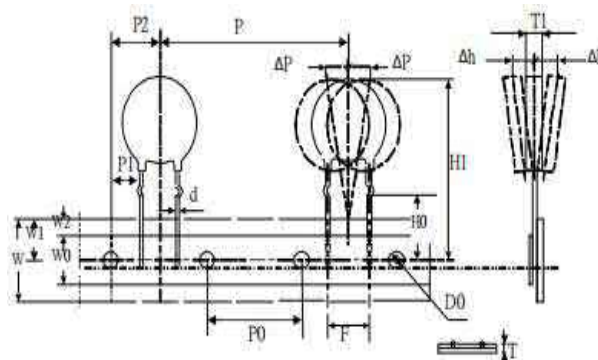

Figure D

(Unit: mm)

Taping Code	Body Size	P0	F	P1	P2	P	H0	H1	W0	W1	W2	W	ΔP	Δh	D0	d	T	Figure
		±0.3	±1	±1	±1.3	±1	±0.5	Max	±1	+0.75/-0.5	Max	±1	Max	Max	±0.2	±0.05	±0.2	
A (P0:12.7)	10	12.7	7.5	8.55	12.7	25.4	16	36.0	12	9	3	18	1.0	2.0	4	0.8	0.6	A
E (P0:15)		15.0	7.5	3.35	7.50	15.0	16	36.0	12	9	3	18	1.0	2.0	4	0.8	0.6	B
A (P0:12.7)	14	12.7	7.5	8.55	12.7	25.4	16	40	12	9	3	18	1.0	2.0	4	0.8	0.6	C
E (P0:15)		15.0	7.5	3.35	7.50	30	16	40	12	9	3	18	1.0	2.0	4	0.8	0.6	D

# Varistor: TVR-U Series

Disc Type Varistor for Surge Protection (Ultra High Surge Series)



## I Type (Inner kink lead)

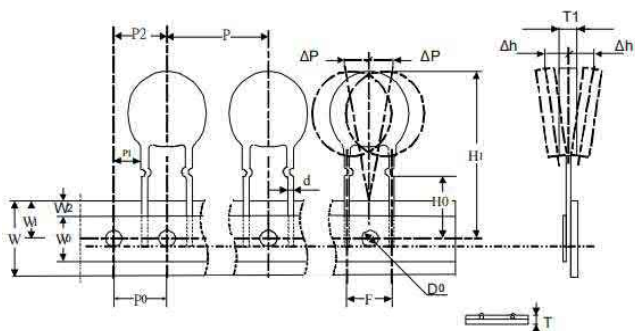

Figure A

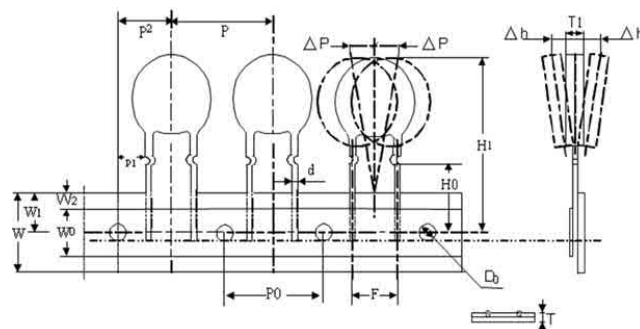

Figure B

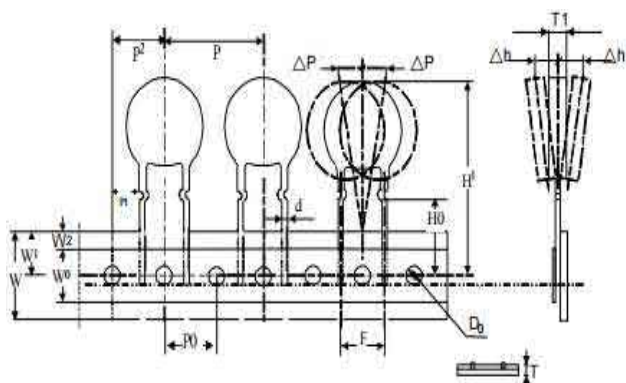

Figure C

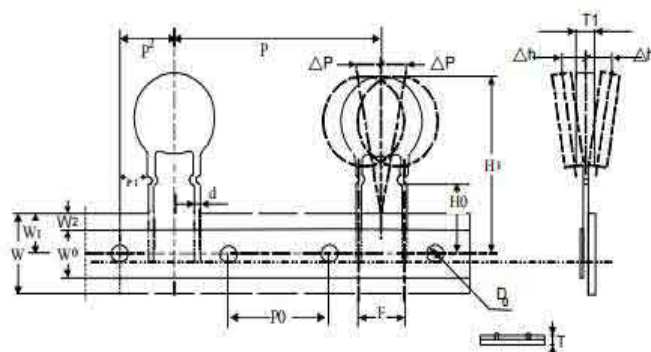

Figure D

(Unit: mm)

Taping Code	Body Size	P0	F	P1	P2	P	H0	H1	W0	W1	W2	W	ΔP	Δh	D0	d	T	Figure
		±0.3	±1	±1	±1.3	±1	±0.5	Max	±1	+0.75/-0.5	Max	±1	Max	Max	±0.2	±0.05	±0.2	
A (P0:12.7)	10	12.7	7.5	8.55	12.7	25.4	16	36.0	12	9	3	18	1.0	2.0	4	0.8	0.6	A
E (P0:15)		15.0	7.5	3.35	7.50	15.0	16	36.0	12	9	3	18	1.0	2.0	4	0.8	0.6	B
A (P0:12.7)	14	12.7	7.5	8.55	12.7	25.4	16	40	12	9	3	18	1.0	2.0	4	0.8	0.6	C
E (P0:15)		15.0	7.5	3.35	7.50	30	16	40	12	9	3	18	1.0	2.0	4	0.8	0.6	D



# Varistor: TVR-U Series

## Disc Type Varistor for Surge Protection (Ultra High Surge Series)



### ■ Quantity

#### ● Bulk Packing

Series	Quantity (pcs/bag)
TVR10-U (241~751)	200
TVR10-U (781~112) TVR14-U (241~112)	100

#### ● Reel Packing

Series	A (mm)	Quantity (pcs/reel)
TVR10-U (201~391)	46	700
TVR10-U (431~561)		600
TVR10-U (621~112)		500
TVR14-U (241~331)	55	750
TVR14-U (361~621)		500
TVR14-U (681~112)		350

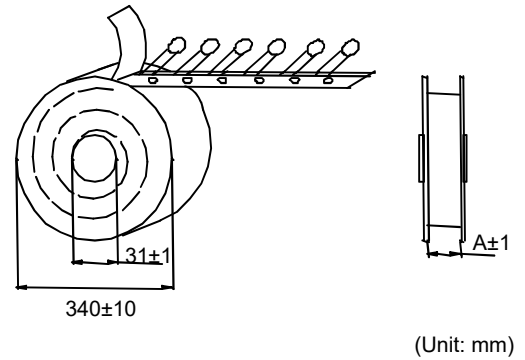

#### ● Ammo Packing

Series	Quantity (pcs/reel) P0=12.7mm	Quantity (pcs/reel) P0=15mm
TVR10-U (201~361)	600	850
TVR10-U (391~621)	550	750
TVR10-U (681~112)	400	650
TVR14-U (241~271)	650	550
TVR14-U (301~561)	450	400
TVR14-U (621~112)	350	300

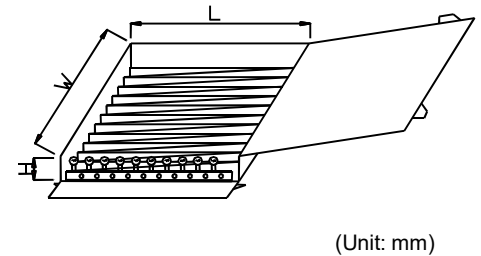

Series	W±5	L±5	H±5
TVR10-U & TVR14-U	275	345	55

# Varistor: TVR-U Series

## Disc Type Varistor for Surge Protection (Ultra High Surge Series)

---



### ■ Warehouse Storage Conditions of Products

- Storage Conditions:
  1. Storage Temperature:  $-10^{\circ}\text{C} \sim +40^{\circ}\text{C}$
  2. Relative Humidity:  $\leq 75\% \text{RH}$
  3. Keep away from corrosive atmosphere and sunlight.
- Period of Storage: 1 year